

VESTEL

MOBILITY



ELECTRIC VEHICLE CHARGER EVC16 SPICA SERIES

Installation Guide



CONTENTS

1 - SAFETY INFORMATION	2
1.1 - SAFETY WARNINGS	2
1.2 - FIRE FIGHTING INSTRUCTIONS FOR ELECTRIC VEHICLE CHARGING STATION	4
1.3 - GROUND CONNECTION WARNINGS	4
1.4 - POWER CABLES, PLUGS, AND CHARGING CABLE WARNINGS	4
1.5 - PROTECTIONS REQUIRED BEFORE SYSTEM	5
2 - GENERAL SPECIFICATION.....	6
3 - GENERAL INFORMATION.....	7
3.1 - INTRODUCTION OF THE PRODUCT COMPONENTS.....	7
3.2 - DIMENSIONAL DRAWINGS	8
4 - REQUIRED EQUIPMENT, INSTRUMENTS AND ACCESSORIES	9
4.1 - SUPPLIED INSTALLATION EQUIPMENT, TOOLS AND ACCESSORIES.....	9
4.1.1 - SUPPLIED BY INSTALLER.....	9
4.2 - RECOMMENDED EQUIPMENT AND TOOLS	10
5 - TECHNICAL SPECIFICATION.....	11
6 - USER INTERFACE & AUTHENTICATION.....	12
7 - CONNECTIVITY	12
8 - MECHANICAL SPECIFICATIONS	12
9 - ENVIRONMENTAL SPECIFICATIONS.....	13
10 - CHARGING STATION INSTALLATION.....	13
10.1 - UNPACK THE CHARGING STATION	14
10.2 - FOUNDATION, ALIGNMENT, LAYOUT	15
10.3 - ESTABLISHMENT OF THE STATION BY PREPARING THE CONCRETE AND ANCHOR PLATE ...	18
10.4 - OPENING THE FRONT COVERS	20
10.5 - CABLE ASSEMBLY	20
10.5.1 - OPENING THE FRONT COVER AND CABLE CONNECTION	20
10.5.2 - SIM CARD CONNECTION (OPTIONAL)	22
10.6 - COMMISSIONING	20
10.6.1 - CONNECTING OCPP THROUGH ETHERNET NETWORK	23
10.6.2 - CONNECTING TO THE SAME NETWORK WITH THE ETHERNET PORT	23
10.6.3 - OPENING WEB CONFIGURATION INTERFACE WITH BROWSER	24
10.6.4 - WEB CONFIGURATION INTERFACE	25
10.6.4.1 - GENERAL SETTINGS	26
10.6.4.2 - OCPP SETTINGS	27
10.6.4.3 - NETWORK INTERFACES.....	28
10.6.4.4 - POWER MANAGEMENT	29
10.6.4.5 - SYSTEM MAINTENANCE	29
10.7 - CLOSING THE COVER	30
11 - PERIODIC MAINTENANCE LIST	31
12 - WIRELESS LAN TRANSMITTER SPECIFICATIONS	33

1 - SAFETY INFORMATION



CAUTION THE RISK OF ELECTRIC SHOCK



CAUTION: THE ELECTRIC VEHICLE CHARGER CAN ONLY BE INSTALLED BY A LICENSED OR EXPERIENCED ELECTRICIAN BY THE ELECTRICAL REGULATIONS AND STANDARDS OF ANY RELATED REGION OR COUNTRY.



CAUTION



The AC grid connection and the electric vehicle charger's load plan are examined and approved by the electrical regulations and standards of the related region or country determined by the authorities.

In the installation of multiple electric vehicle chargers, the load plan will be determined accordingly. The manufacturer shall not be liable in any way, directly or indirectly, for damages or risks caused by the errors that may occur due to AC grid connection or load planning.

CAUTION: FOR DEVICES WITHOUT EMERGENCY BUTTON;

If any suspicious or emergency situation arises at the charging station aside from normal operation, start by halting the charging process through the vehicle (using the appropriate switch or button, which may vary depending on the model), and then disconnect the socket. As an alternative option, consider switching off the MCCB or RCCB in the panel where the product is energized by the installer.

IMPORTANT - Read these instructions fully before installation or operation.

1.1 - SAFETY WARNINGS

- Keep this manual in a safe place. These safety and operating instructions should be kept in a safe place for future reference.
- Check the voltage specified on the rating plate and do not use the charging station without the proper mains voltage.
- Do not continue to use the unit if you have any doubts as to whether it is working normally. If the device has been damaged in any way, switch off the main supply circuit breakers (MCCB and RCCB) in the upstream distribution board. Consult your local dealer.
- During charging, the ambient temperature range (without direct sunlight) should be between -35°C and $+55^{\circ}\text{C}$ and the relative humidity should be between 5% and 95%. Use the charging station only within the specified operating parameters.
- The device location should be consciously selected in order to prevent the charging station from overheating. High temperature caused by direct sunlight or heating sources during use may cause the charging current to decrease or the charging process to be temporarily interrupted.
- The charging station is made for indoors and outdoors. It can also be used in public open spaces.

- To reduce the risk of fire, electric shock, or product damage, do not expose the unit to heavy rain, snow, lightning storms or other harsh weather conditions. Furthermore, liquids should not be spilled or splashed on the charging station.
- Do not touch the end terminals of the charging station, the electric vehicle connector and other dangerous current parts with sharp metal objects.
- Avoid exposing the unit to heat sources and place it away from flammable, explosive, hard or caustic materials, chemicals or steam.
- Explosion Risk. This equipment contains internal spark or spark-generating parts and must not be exposed to flammable vapours. It should not be placed in lowered or below ground level locations.
- Make sure that the specified Current Switch and RCD are connected to the building mains to prevent the risk of explosion and electric shock.
- The base part of the charging station should be at (or above) ground level.
- Adapters or converter adapters cannot be used. Cable extension sets cannot be used.
- Use this product at an altitude of not more than 2000 meters above sea level.
- Do not place objects containing liquids, such as glasses and bottles, on the product.
- Against the risk of choking, keep the plastic packaging materials out of the reach of babies, small children and pets.
- Do not wash the device with water.
- Do not use abrasive fabrics, wet cloths, alcohol or detergents. Microfiber fabric is recommended.
- Keep the door lock key, which enables the product panel to be opened and prevents access to electrical parts, out of the reach of small children.
- It should be kept in its original box to prevent damage to device components during transport.
- Defects and damages that occur during transportation after the device shipment to the customer are not covered by the warranty.
- The allowed current value of the service socket is a maximum of 10A.
- Please adhere to the rope warnings outlined in the “Basic Alignment and Layout” section, especially when transporting the product.



WARNING: Persons (including children) who are physically, perceptually or mentally incompetent or inexperienced should not use electrical devices without the supervision of a person responsible for their safety.



CAUTION: This vehicle charger is designed only for charging the electric vehicles that do not require ventilation during charging.

1.2 - FIRE FIGHTING INSTRUCTIONS FOR ELECTRIC VEHICLE CHARGING STATION

- **Personal Safety:** If you observe a fire or notice any danger signs, prioritize your safety above all else. Do not take unnecessary risks.
- **Notify Emergency Services Immediately:** Contact your local emergency services. Dial the emergency number 998 or 112.
- **Stopping the Charging Process:** If it is safe, disconnect the charging cable from the vehicle and the charging station.
- **Use of Fire Extinguishing Agents:** If a fire extinguisher or other firefighting equipment is nearby and you are trained to use it, attempt to extinguish the fire. However, never risk your own safety.
- **Avoid Direct Contact with Fire:** Do not try to extinguish a fire unless you have the appropriate equipment, training, or knowledge, or if the fire is exceptionally large or dangerous.
- **Move Away from the Station:** If the fire cannot be controlled or is intensifying, evacuate from the charging station while maintaining a safe distance.
- **Avoid Inhaling Smoke:** Try to avoid breathing in smoke. If possible, cover your nose and mouth with a damp cloth or clothing.
- **Warn Others in the Area:** Alert others nearby about the fire hazard and urge them to evacuate the area.
- **Wait for Emergency Services:** After safely evacuating the area, wait for emergency services to arrive in a secure location.
- **Do Not Return to Station Facilities:** Do not re-enter the charging station building until emergency services have concluded their operations.
- **Reporting the Incident:** Contact customer support to report the incident.

Remember, safety is always the top priority. In the event of a fire, always seek guidance from local emergency services and adhere to their instructions.

1.3 - GROUND CONNECTION WARNINGS

- The charging station should be connected to a central grounding system. The grounding conductor entering into the charging station should be connected to the equipment grounding lug inside the charging station. This should be powered by the circuit conductors and connected to the equipment grounding rod or to the guide member at the charging station. Connections to the charging station are in the charge of the installers and purchasers.
- Connect it only to correctly grounded plugs to reduce the risk of electric shock.
- **WARNING :** Make sure that the charging station is permanently and properly grounded during installation and use.

1.4 - POWER CABLES, PLUGS, AND CHARGING CABLE WARNINGS

- Note that the plugs and sockets in the charging station are compatible.
- A damaged charging cable may cause a fire or electrical shock conditions. Do not use this product if the Flexible Charging cable or vehicle cable is worn, has frayed insulation, or shows any different signs of damage.
- Make sure the charging cable is well placed, thus you will not step on and trip over the cable or the cable will not damage or subject to stress.
- Do not forcibly pull on the charging cable or damage the cable with sharp objects.
- Never touch the electric cable/plug or vehicle cable with wet hands as this may cause a short circuit or electric shock.

- To avoid the risk of fire or electric shock, do not use this device with an extension cable. In case of damage to the mains cable or vehicle cable, the cables should be replaced by the manufacturer, service agency or similar qualified persons to prevent any hazards.
- Use appropriate protection while connecting the device to the main power distribution cable.

1.5 - REQUIRED UPSTREAM PROTECTIONS

- Class I/B Lightning Protection should be connected to the upstream distribution board. It is recommended that the cable length between the charger and the protection device be at least 10m. *The charger is equipped with a Class II/Type C Surge Protective Device (SPD).
- To prevent the residual current, Type A residual current relay with toroidal sensor should be used on the panel before the device. The minimum current sensitivity should be set to 300mA.
- MCCB (Thermal Magnetic Circuit Breaker) should be connected to the upstream distribution board.
- A single-pole 20 A MCB should be installed on the Neutral line in the upstream supply cabinet.

Model	Power	Input Voltage	Maximum Input AC current	Recommended Minimum Neutral Conductor Cross-Section (Cu)
EVC16-DC80CC	80kW	400V (nom.)	123A	16mm ²
		360V (-%10)	137A	

- Cable cross-sections must be selected by the installer in accordance with local and international standards, considering the specified maximum AC input current values, minimum allowed input voltage values, installation distances, and mounting location conditions.
- The PE cable cross-section should be at least half of the phase cable cross-section.
- It is recommended to use a CAT6 SFTP Ethernet cable.
- Cables must be suitable for outdoor use.
- Cables must be UV-protected and suitable for installation in underground conduits in accordance with local regulations.
- The AC input cable glands supplied with the product are suitable for cables with diameters in the range of 18–25 mm.

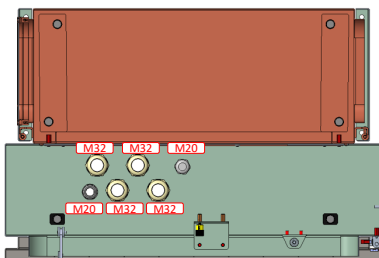

- Recommended cable lug dimensions for AC line connections are provided below.

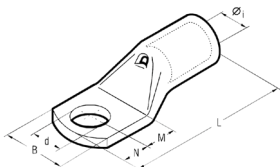

	LUG	Øi (min)	B	M	N	L	d	Tightening Torque
AC phases and PE	M8	10,0 mm	19,0 mm	9,0 mm	8,0 mm	42,5 mm	8,4 mm	11 Nm

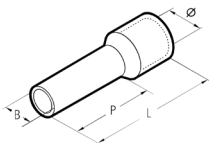

	End Sleeves	Øi (min)	B	P	L	Tightening Torque
Neutral	16 mm ²	9,3 mm	5,9 mm	12,0 mm	22,7 mm	7,5 Nm

2 - GENERAL SPECIFICATION

Model Name	<u>EVC16-DC Series (Name Coding: EVC16-DC****)</u> 1st Asterisk (*) : Rated Power 80 : 80 kW DC Power Output 2nd Asterisk (*) : DC output combination 1 C : CCS Output 3rd Asterisk (*) : DC output combination 2 C : CCS Output 4th Asterisk (*) : MID Meter Option Blank : No DC Meter MID : MID meter -EICH : Eichrecht Meter
	Cabinet EVC16-DC80

3 - GENERAL INFORMATION

3.1 - INTRODUCTION OF THE PRODUCT COMPONENTS

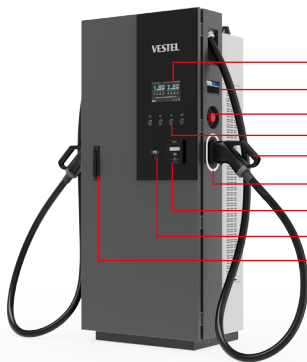

- 1- Display
- 2- MID Meter (optional)
- 3- Emergency Stop Button (optional)
- 4- Buttons
- 5- CCS Output Plug
- 6- LED Indicator
- 7- Payment Terminal (optional)
- 8- RFID Card Reader
- 9- Access Cover for CTB, PLC Card and HMI

All products images are given for representative purpose only.

3.2 - DIMENSIONAL DRAWINGS

Front, Side and Top View

RIGHT SIDE VIEW

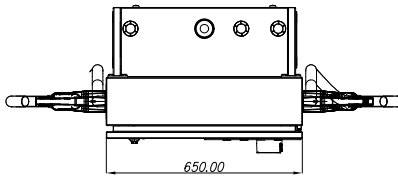
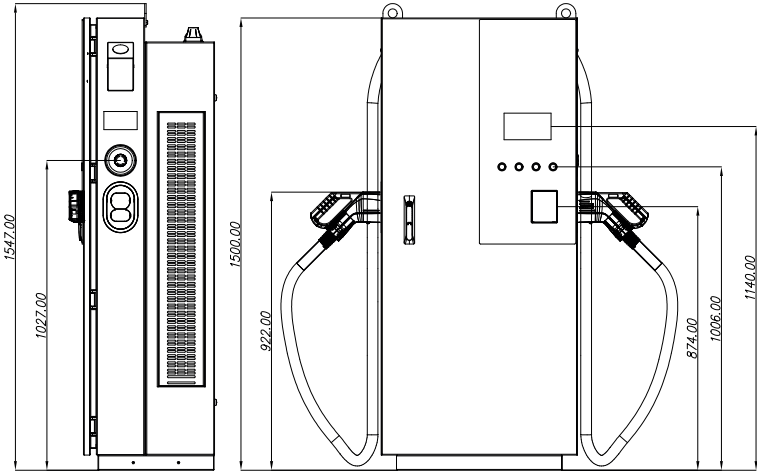

FRONT SIDE VIEW





TOP SIDE VIEW

4 - REQUIRED EQUIPMENT, INSTRUMENTS AND ACCESSORIES













4.1 - SUPPLIED INSTALLATION EQUIPMENT, TOOLS AND ACCESSORIES

Special Switch M50 x M40	
Product control with internet connection(optional)	
1 set (x2) Lock Key	

4.1.1 - SUPPLIED BY INSTALLER

M16 Steel Dowel x4	
M20 special anchor bolt set (4 pcs) - Grade 8.8 (optional)	
Anchor plate (1 pc) - S235JR Steel + Hot Dip Galvanizing ($\geq 70 \mu\text{m}$) (optional)	

4.2 - RECOMMENDED EQUIPMENT AND TOOLS

			
Ø16 Drill Bit	Hammer Drill	PC	Phillips Screwdriver
			
13(M8) , 17(M10), 19(M12) Wrench	RJ45 crimping tool	Cat5e or cat6 ethernet cable	Hammer
			
M16 Steel Dowel x4	RJ45 Male Connector	T25 Screwdriver	20 - 200 Nm D:40mm H:43mm

5 - TECHNICAL SPECIFICATION

Model		EVC16-DC Series
IEC Protection class		Class - I
IEC EMC Class		IEC 61000-6-3 Class B - Residential (Emission) IEC 61000-6-2 Industrial (Immunity)
Input Rated Voltage and Current Value	Input Rate	230/400 Vac $\pm 10\%$, 50/60 Hz, 125A
	Connection	3L+N+PE (TN-S, TN-C-S or TT)
	Power Factor	> 0.98
	Efficiency	> %95
	Residual Current Protection	230Vac RCBO 1P+N, Type A, 30mA (system)
	Standby Power Consumption	< 80 W
CCS Output - 1	Max. Power	80kW • 1 x 80kW • 2 x 40kW
	Voltage Range	200 – 920Vdc
	Maximum Current	266 A • 1 x 80kW 133A • 2 x 40kW
	Interface Compatibility	IEC62196-1 / 3 IEC 61851-1 / 23 / 24 ISO 15118-1 / 2 / 3 DIN 70121
CCS Output - 2	Max. Power	80kW • 1 x 80kW • 2 x 40kW
	Voltage Range	200 - 920 Vdc
	Maximum Current	266 A • 1 x 80kW 133 A • 2 x 40kW
	Interface Compatibility	IEC62196-1 / 3 IEC 61851-1 / 23 / 24 ISO 15118-1 / 2 / 3 DIN 70121

6 - USER INTERFACE & AUTHENTICATION

Display	7" Color TFT LCD without Touch Screen (16:9)
User Interface	Illuminated buttons
RFID Reader Module	ISO/IEC 14443A/B and ISO/IEC15693
Payment module (Optional)	Contactless Credit Card kit options
Cable Management	N/A
DC Meter (Optional)	MID meter Certified
Eichrecht Approval (Optional)	Eichrecht conformity for Germany
Plug&Charge	ISO15118

7 - CONNECTIVITY

LAN Connectivity	Ethernet
WLAN Connectivity	802.11 a/b/g/n/ac
Mobile Connectivity	GSM 900/1800 UMTS 900/2100 LTE Band 1/3/7/8/20/28A
OCPP Specification	OCPP 1.6 J

8 - MECHANICAL SPECIFICATIONS

Material	Metal Panel	
Protection Degree	Ingress Protection Impact Protection	IP54 IK10
Cooling	Forced Air Cooling Fan	
Cable Length	CCS: 3,5 m CCS: 5,0 m (option)	
Dimensions (Product)	1500 mm (Height) x 650 mm (Width) x 423 mm (Depth)	
Dimensions (Packed version)	1750 mm (Height) 970 mm (Width) 560 mm (Depth)	
Weight (Product)	Net: 180 kg	
Packed Weight	With Packing : 213 kg	

9 - ENVIRONMENTAL SPECIFICATIONS

Operating Condition	Temperature	-35 °C to + 55 °C (Derating is applied over +40 °C to +55 °C) For products with credit card option-20 °C to + 55 °C
	Humidity	5% to 95% (Relative humidity, non-condensing)
	Altitude	0 - 2,000m

10 - CHARGING STATION INSTALLATION

It is recommended that the screws inside the product exceed 240 hours in the Salt Fog Testing according to the ASTM B117 Method. It is recommended that the screws outside the product exceed 720 hours.



WARNING: ELECTRIC SHOCK OR INJURY HAZARD. DISCONNECT THE MAINS SUPPLY OF THE CHARGING STATION BEFORE ANY INSTALLATION STEP



WARNING : TO PREVENT INJURIES OR DAMAGE TO THE CHARGING STATION, MAKE SURE THE INSTALLATION AREA IS SUITABLE AND THAT THE FLOOR CAN RESIST THE WEIGHT OF THE CHARGING STATION.

10.1 - UNPACK THE CHARGING STATION

Unpack the charging station as shown in the figure below.

Note that the front and top covers are marked as shown in the figures.

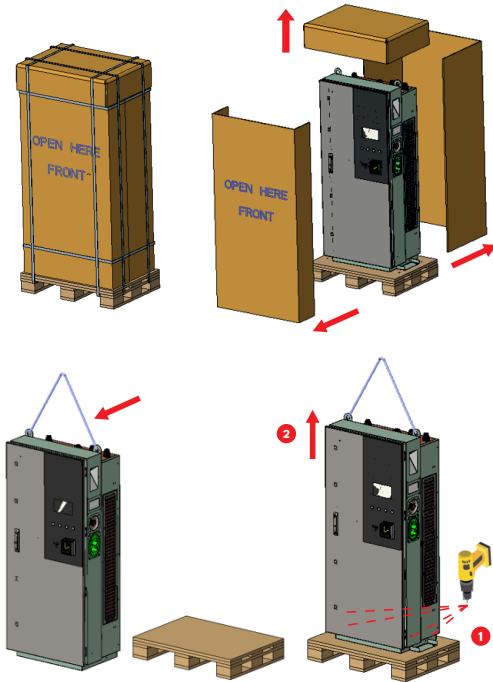

All products images are given for representative purpose only.

10.2 - FOUNDATION, ALIGNMENT, LAYOUT

The dimensions of the concrete foundation are as shown below:

NOTE: Anchoring to the ground with steel dowels is the standard method.

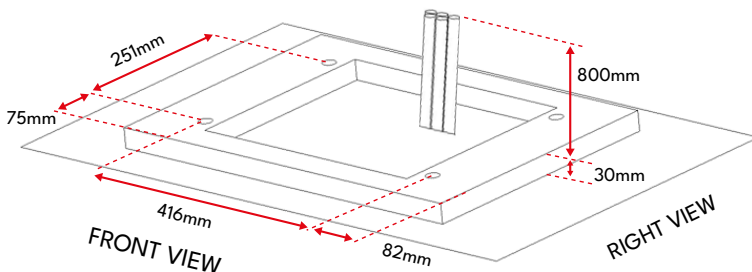

1. For installation, a minimum distance of 1 meter must be left from the right and left side of the device.
2. Dig a foundation pit in the ground according to the dimensions of the concrete foundation shown in the figure.
3. Drill a rectangular hole from top to bottom in the concrete foundation for the cables (3P+N+PE and Communication) from the mains supply. The dimensions and location of the concrete foundation are shown in the Figure.
4. The upper surface of the foundation should be at least 30mm above the ground.
5. Open the front cover of the product with the switches provided by turning the handle counterclockwise at a wide angle.
6. For the cable group in the cabinet, a cable length of 80 cm should be provided above the foundation.
7. Drill 4 holes on the concrete foundation with the dimensions shown in the figure and drive the M16x145 expansion bolt into these holes as shown in the Figure.
8. Remove the bottom plates (left and right) by unscrewing the plates.
9. In cases where the product needs to be transported; During lifting, it is necessary to use 2 ropes of min. 540mm (if a single rope of min. L=1080mm is used, the rope should be fixed at the middle lifting part).

During lifting, there should be a minimum angle of 60 degrees at both rope ends, as shown in the image. Using a shorter sling will cause damage to the product.

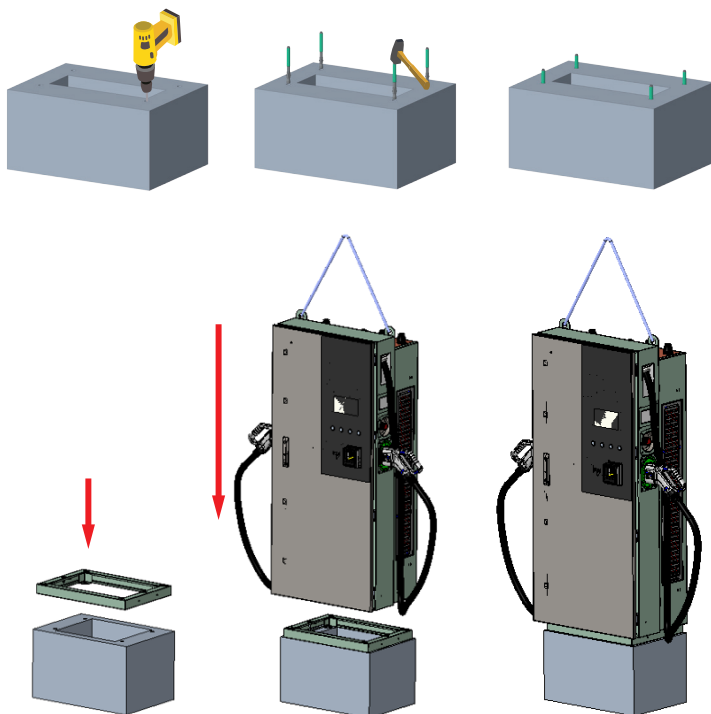
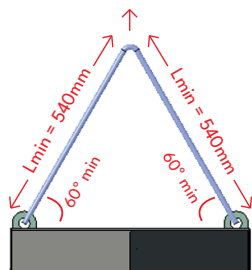

All products images are given for representative purpose only.

Hole Drilling Diameter: $\varnothing 16$ mm, Drilling Depth: 155mm (Torque: 200Nm)



M16

10. Remove the eye bolts after placing the charging station. Tighten the screws with setscrews as shown in the figure.

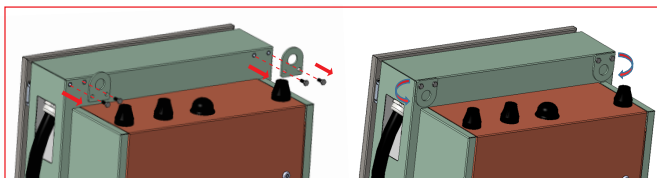

All products' images are given for representative purpose only

Concrete Dimension:

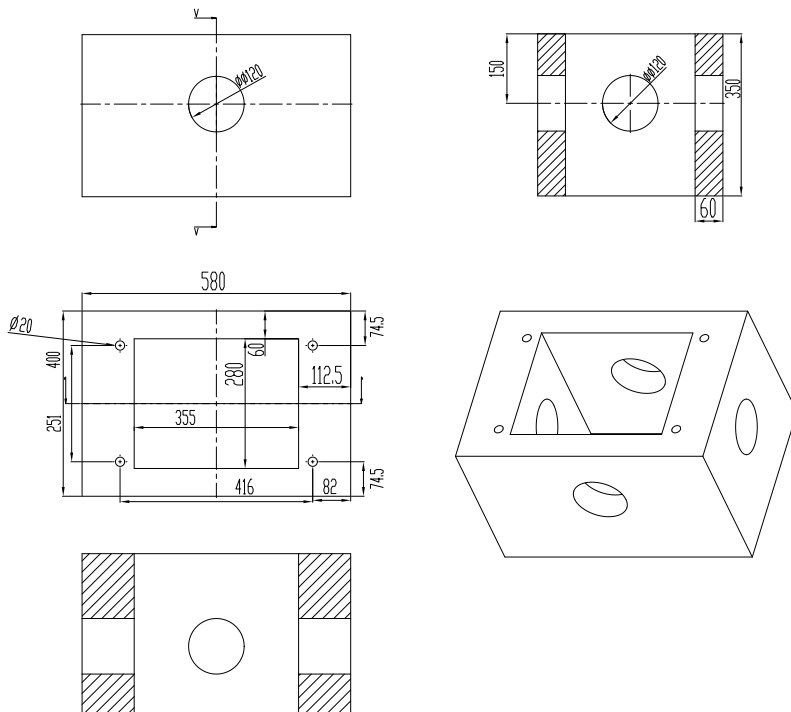

10.3 - ESTABLISHMENT OF THE STATION BY PREPARING THE CONCRETE AND ANCHOR PLATE

Make sure that the materials and installation procedures used for the concrete foundation comply with the local building codes and safety standards.

NOTE: The installer will supply this embedded metal plate and anchor system, and we are presenting this installation method as an alternative to comply with legal requirements.

For the Preparation and Mounting of the Anchor Plate, the following three steps should be followed as also shown in the figures:

1. Attach each nut one by one to each bolt as shown.
2. Attach the anchor plate to the bolts as shown in the figure.
3. Mount the nuts on the anchor bolt to secure with the bolts.

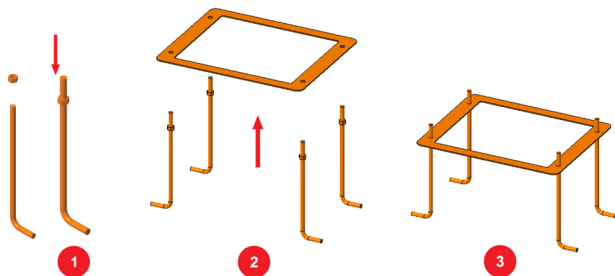

For the preparation of the installation site and wiring, the following steps should be followed as also shown in the figures:

1. Dig a pit for the anchor bolts and plate assembly (dimensions as: 400x580x320 – DxWxH mm). The ground of the pit should be grinded and horizontal.
2. Place the anchor arrangement in the pit.
3. Before the concrete is poured, the cables should be placed in the middle part and pulled through the sheet hole. Pull the supply cable and possible data cable through the floor mounting box cable glands and also through the mounting box cable hole. A minimum clearance of 500 mm for the AC mains cable and 0.5 meters for the ethernet cable should be left from the ground surface of the mounting box.
4. Fill the pit with concrete. Then set the mounting assembly as shown in the picture. The upper surface of the 2nd bolt should be at the concrete level. A level indicator can be used while adjusting.
5. Allow the concrete to solidify, note that the surface remains firm and flat during the process.
6. Place the charging station on the anchor plate as shown in the figure. Pass the cables through the cable glands.
7. Fix the charging station to the surface as shown in the figure by joining the metal holes and nuts on the bottom cover.
8. Tighten the cable glands.
9. The base part of the Charging Station should be at least 30mm above the ground.

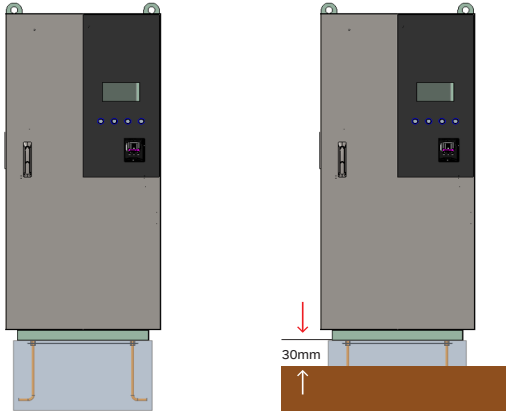
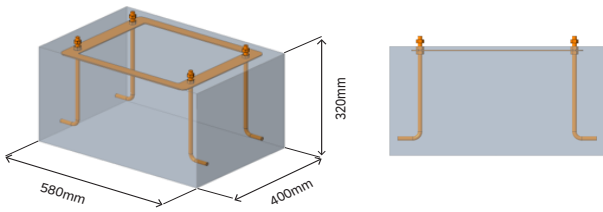

Anchor Plate Dimension:

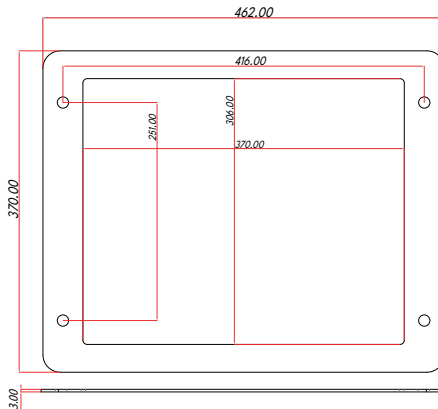

10.4 - OPENING THE FRONT COVERS

Use the key provided to open the front cover.

Pull the handle up slightly. Turn the handle to the right of the charging station at a wide angle.

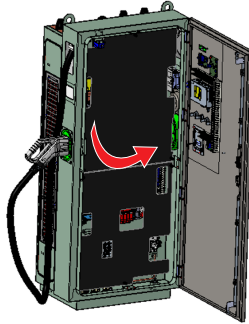

All products images are given for representative purpose only.

1. Insert the cover opening key into the cover lock.
2. Turn the key to the right.
3. After turning the key, pull the cover lock apparatus towards you.
4. Turn the opened cover lock apparatus counterclockwise.
5. This way, the cover will open.

10.5 - CABLE ASSEMBLY

10.5.1 - OPENING THE FRONT COVER AND CABLE CONNECTION

1. Open the front cover of the product with the switches provided by turning the handle counterclockwise at a wide angle.
2. Remove the screws and also the insulation plate covering the AC Mains cable in the lower right corner.

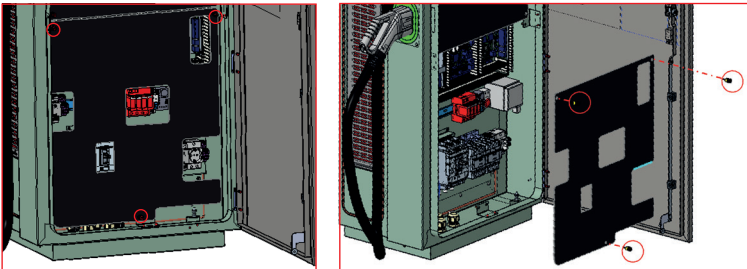

All products images are given for representative purpose only.

Cable lugs positions:

All cable lugs (L1, L2, L3, PE and N) must be selected for the wire size shown in the table section 1.5- Protections Required Before System.

This structure is designed to mount cables with low flexibility with cable lugs on the busbar, as shown in the figure. Thus, the midpoints of the cable glands and cable lugs are aligned with the same axis (z-axis), as shown in the figure. Installation should be performed as shown in the figure.

Contact surface of cable gland nuts and cable lugs:

The surface contact of the cable lugs and cable glands is shown in brown in the figure. The mounting surface of the cable lugs corresponds to 92% of the surface data shown in the cable lugs data sheet compatible with a cable cross-section.

3. Pass the cables through the cable glands at the bottom of the charging station.
4. Connect the AC Mains cables. First, connect the "PE Line" cable, then the "Line N" cable, and finally the three phase cable ("Line 1", "Line 2", "Line 3") as shown in the figure:

Phase sequence is clockwise.

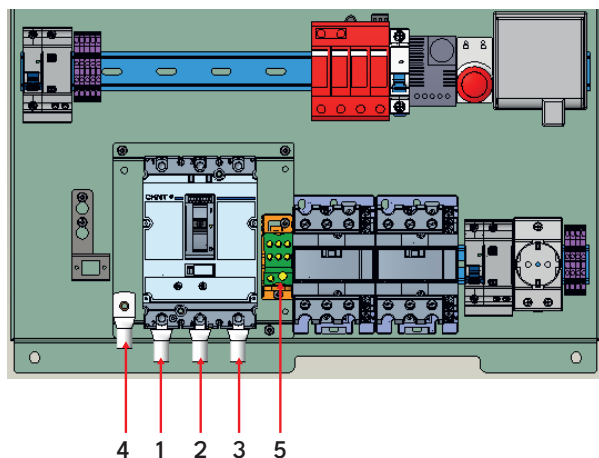

1	Line 1
2	Line 2
3	Line 3
4	PE
5	N

5. Tighten the cable glands with an adjustable wrench. (25Nm)

10.5.2 - SIM CARD CONNECTION (OPTIONAL)

See “Opening the front covers” section and insert the Micro SIM card into the cellular communication module SIM card slot as shown in the figure below.

Ghost OCPP provides the communication between the charging station and the central system via a dedicated APN cellular network. With this system, the manufacturer will have the capability to remotely control any device that has been installed in the field and supported by Ghost OCPP at any time. Thus, controlling the instant status of the products, sending remote commands to the product (restarting the product, diagnostic message), usage data and logs related to the product will be accessible 24/7. With this process, device intervention and controls in the field can be performed quickly/effectively. Within the scope of Ghost OCPP, the manufacturer inserts the SIM card into the Ghost OCPP card and sends it to the field after activating. The management of the Ghost OCPP card is in the charge of the manufacturer.

OCPP Connection GSM Module

Remote monitoring GSM Module

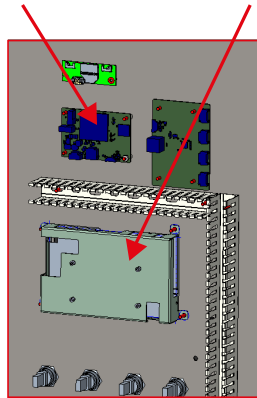

10.6 - COMMISSIONING

10.6.1 - CONNECTING OCPP THROUGH ETHERNET NETWORK

In order to connect your device to the internet over the cable and make the necessary adjustments, you must first prepare the ethernet cable and plug this cable into the locales that should be on the device.

Insert Ethernet cable through the cable gland. Terminate the Ethernet cable with RJ45 terminal and connect the cable to the Ethernet port as shown below.

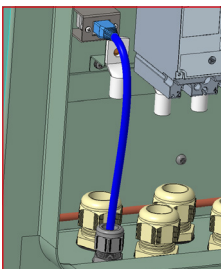

10.6.2 - CONNECTING TO THE SAME NETWORK WITH THE ETHERNET PORT

To access the Web Config User Interface, you need to connect your PC and CV charger to the same ethernet switch or connect the EV charger directly to your PC.

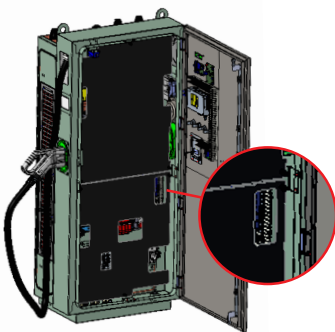

Open the charging station. The default IP address of the HMI card is 192.168.0.10. Therefore, you need to assign a static IP address to your PC, which is on the same network as the HMI card. You should assign a static IP address to your PC on the 192.168.0.0/254 network; The IP address should be between 192.168.0.1 and 192.168.0.254.

For instance, 192.168.0.11 can be assigned to your PC as a static IP.

Press the next button to continue.

10.6.3 - OPENING WEB CONFIGURATION INTERFACE WITH BROWSER

Open your web browser and type 192.168.0.10 which is IP address of HMI board.

You will see login page on your browser;

Each product has a user name and password set as factory configuration.

In this section you can log in to the Web configuration interface by entering the configuration information printed on the label. User Name and Password informations are located on the label pasted to the Quick Start Guide as shown below.

Only for the first login you will be forced to change your password.

You can change password with Change Password Button in WEBUI login page or Administration Password section in the System Maintenance tab.

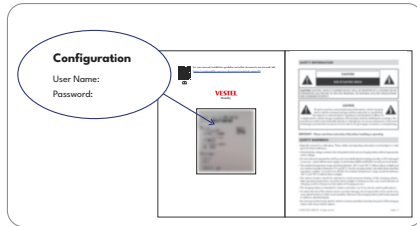

Visual representation is provided

Change Password:

If you click the “Change Password Button“ you will be redirected to the Change Password page.

Your password must be minimum 12 maximum 32 character and it contains at least two uppercase letters two lower case letters two number digits and two special characters.

After typing your current password and new password twice, you will be redirected to the login page again to log in with your new password.

CHANGE PASSWORD

Your password must be minimum 12, maximum 32 characters and it contains at least two uppercase letters, two lower case letters, two number digits and two special characters.

User Name:

Current password:

New password:

Confirm new password:

[Back to Login](#)

10.6.4 - WEB CONFIGURATION INTERFACE

You can change the web configuration interface language and log out of the web configuration interface with the buttons in the upper right corner of the page.

MAIN PAGE	<p>The Main page provides an overview of the key system information and connection status of the EVC device. Below are the descriptions of each displayed parameter:</p> <p>CP Serial Number: Unique serial number of the device. It is used for device authentication and remote management.</p> <p>HMI Software Version: The software version of smart board (HMI) that runs the device's touchscreen interface.</p> <p>Power Board Software Version: The version of the software that controls power management and charging operations of device.</p> <p>PLC Software Version: The software version of power line communication board.</p> <p>VCR Software Version: The software version of the VCR (Voltage Current Resistance) board.</p> <p>OCPP Software Version: The version of the Open Charge Point Protocol (OCPP) software, which enables communication with the charging network management system.</p> <p>Duration after Power On: The total time (in hours, minutes, and seconds) that has passed since the device was last powered on. Useful for uptime tracking and performance monitoring.</p> <p>Connection Interface: The current communication method used by device. It can be Ethernet, WLAN (Wi-Fi), or Cellular.</p> <p>OCPP Device ID: Unique identification number used by device when communicating with OCPP server.</p> <p>Connector ID 1 Status: The current status of charging Connector 1 (e.g., Available, Plugged, Charging, Faulted).</p> <p>Connector ID 2 Status: The current status of charging Connector 2 (e.g., Available, Plugged, Charging, Faulted).</p>
------------------	--

10.6.4.1 - GENERAL SETTINGS

Default Interface Languages	HMI display language and web interface language can be selected from the general settings page.
Display Settings	<ul style="list-style-type: none"> • Static - Set brightness/outdoor lighting to a fixed level, options include Low/Medium/High • Reduced Brightness in Inactive Mode - Sets automatic brightness dimming when the screen is not in use. This option can be enabled or disabled. • Minimum Brightness Value - Defines the minimum brightness for inactive mode. • Show Charge Point ID - Displays the charge point ID on screen (can be enabled/disabled).
Display Logo (Optional)	The user can upload left and right logos to display in the app UI and toggle their visibility using a switch button.
Tilt Threshold	<p>The user can change the tilt threshold in angle. The tilt threshold as an angle is set to 30 for all angles by default.</p> <p>Tilt Threshold Range: 12 - 90</p>
Prepaid Settings	<p>Prepaid Settings are the settings that enable operation with pre-authorization (prepaid) via credit card for the electric vehicle charging service when the Credit Card Enable feature is activated.</p> <p>Within this scope, the system places a pre-authorization hold for a specified amount on the credit card before the charging session starts, and the cost of the energy consumed during charging is calculated based on this amount.</p> <ol style="list-style-type: none"> 1. When Credit Card Enable is enabled, the charging session is started using a credit card. 2. Before charging starts, the amount defined in the Provision field is charged as a pre-authorization hold on the credit card. 3. During charging, the consumed electrical energy is calculated based on the defined price per kWh. 4. At the end of the charging session, the total amount is collected from the pre-authorized amount; any unused amount is refunded to the card. 5. If the pre-authorization amount is insufficient, the charging session may be automatically terminated. 6. The charging session is valid only for the configured connector type. 7. Pricing information may be changed by the operator. <ul style="list-style-type: none"> • Credit Card Enable: Enables credit card payment and pre-authorization operation. • Provision: Amount to be held as a pre-authorization on the credit card. • Energy Unit Price per kWh: Energy unit price per kWh. • Prepaid ID Tag: User identifier associated with the credit card

Display QR Code	The user can update the QR Code Settings for each connector on the device. QR Code can be enabled/disabled and if enabled, a limiting value for the QR Code String can be set.
Customer Service Number	You can reach customer service number from WEB UI screen. You can enable or disable it to display on the screen.
Timezone	The user can set the timezone.

10.6.4.2 - OCPP SETTINGS

The required settings for the OCPP connection (activating and deactivating the OCPP connection, entering the connection address, entering the charging station ID, etc.) are made on this page.

Adding a New RFID Card:

In the **Authorization Mode** dropdown menu, select **Authorize with Whitelist** from OCPP Settings tab in the interface. In the **Manage RFID Local List** section, enter the unique ID of the RFID card you want to authorize into the text field.

Once entered, click the **Add** button to include the card into the list. Press the save button to apply the changes.

To apply the update, a **Hard Reset** must be performed. During this process, a confirmation prompt will appear – be sure to confirm the action by selecting **Confirm**.

Once the product restarts, return to the same configuration page and ensure that the newly added card appears in the RFID list.

10.6.4.3 - NETWORK INTERFACES

There are three types of network interfaces in this page; Cellular, Ethernet (LAN), Wi-Fi. Select interfaces' modes as "Enabled" if you want to activate it.

You should fill all spaces in suitable formats.

FIREWALL

Input and output policies determine how the network is operated. Default policies in this area should be adjusted as needed by authorized people. Access to the device may be completely blocked after incorrect settings. This is not a software issue but a configuration error.

These policies should be adjusted according to the whitelist or blacklist logic and the necessary rule configuration should be made for the desired situations.

Status

This setting controls the firewall status: "Enable" activates it, while "Disable" deactivates it. The "Disable" option turns off the firewall, preserving the status of all settings.

Incoming Traffic

This policy determines the default behavior for incoming traffic. The "Allow" option accepts all incoming traffic, while the "Deny" option rejects all incoming traffic.

Outgoing Traffic

This policy determines the default behavior for outgoing traffic. The "Allow" option accepts all outgoing traffic, while the "Deny" option rejects all outgoing traffic.

Adding Custom Rules:

Users can add custom firewall rules and select and delete them. To delete a rule, check the box in the "Select" column and click the "Delete" button. Rules are prioritized from top to bottom.

The "Add" button will open a pop-up and the rules will be added to the list by making the necessary settings and pressing "Add".

Policy: This setting determines whether to accept or reject a certain type of traffic. The "Allow" option allows the traffic, while the "Deny" option blocks the traffic.

Direction: This setting determines which direction of traffic the rule applies to. The "Input" option targets incoming traffic, while the "Output" option targets outgoing traffic.

Interface: This setting determines which network interface the rule is applied to. Options include "LAN", "wlan", "Cellular", and "lo".

Protocol: This setting determines which communication protocol the rule is applied to. Options include "tcp", "udp", and "None".

Port: This setting determines which port number the rule is applied to. Users can add as many rules as they want and can edit or delete them as needed. This enhances the flexibility and convenience of your firewall application.

10.6.4.4 - POWER MANAGEMENT

Model Code	The Model Code parameter identifies the charger model based on its nominal DC power rating. Each Model Code value represents a predefined hardware configuration and maximum DC output power.
Charge Point Maximum Power	Maximum Power value is used to set the maximum output power delivered from charging station.
Fail Safe Power	Fail Safe Power Limiting feature is used to limit the station output power when the OCPP Server connection is lost. When feature is enabled, the user can set output power value. The default value is 10 kW.
Power Module Configurations	DC power sharing enabled option is used to allow CPO to decide if power sharing will be active for power modules. Example: For a 60kW product which has 2 30kW power modules, if DC Power Sharing Enabled is set to True, 2 connectors will be available for charging at maximum of 30kW output. If it is set to False, Then only 1 connector will be available for charging and while one of the connectors is in charging state, other connector status will be set to Unavailable.
Connector Settings	Connector type and corresponding maximum output power is displayed under Connector Settings menu.

10.6.4.5 - SYSTEM MAINTENANCE

Log Files	The logs related to the device can be downloaded from this section.
Firmware Updates	The firmware file of device can be uploaded and upgraded.
Configuration Backup & Restore	The device-related configurations can be backed up and restored from this tab.
System reset	You can proceed to this section to perform Hard Reset and Soft Reset.
Administration Password	The administrator password can be changed from this tab.
Factory Default Configuration	You can reset your device to its factory settings.

10.7 - CLOSING THE COVER

1. Place the (left and right) bottom plates and tighten the bolts. (torque value should be 3 Nm.)
2. Make sure the cables and plugs are not damaged.
3. Insert and tighten the screws of the insulation plate covering the AC Mains cable.

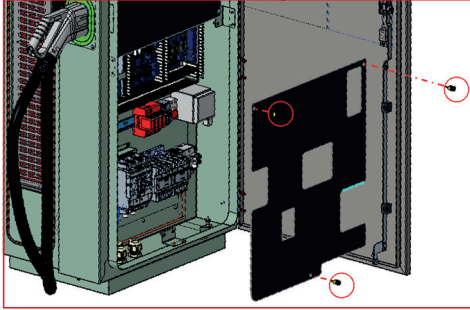

4. Switch the MCCB on.

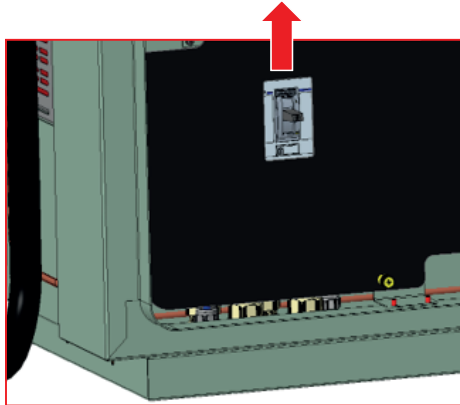

5. As shown in the “Opening the front covers” section, close the front cover of the product with the keys provided by turning the handle clockwise at a wide angle.

11 - PERIODIC MAINTENANCE LIST

	Maintenance Period (year)									
	1	2	3	4	5	6	7	8	9	10
Air filters	R	R	R	R	R	R	R	R	R	R
Plugs	I	I	I	I	I	I	I	I	I	I
Display	C	C	C	C	C	C	C	C	C	C
Distribution elements (MCCB, RCBO)	T	T	T	T	T	T	T	T	T	T
AC input terminals	T	T	T	T	T	T	T	T	T	T
DC relay terminals	T	T	T	T	T	T	T	T	T	T
DC output cable and terminals	T	T	T	T	T	T	T	T	T	T
Fan	I	I	I	I	I	I	I	I	I	I
Body	C	C	C	C	C	C	C	C	C	C
Grounding resistance	M	M	M	M	M	M	M	M	M	M

C : Clean

I : Inspect (check, approve, clean, tighten or replace if necessary)

M : Measure

T : Tighten

R : Review

Air filters

Air filters should be replaced every year when going for maintenance.

Plugs

All spark plugs should be checked when going for maintenance. If the plug is broken or cracked, it should be replaced. Furthermore, a charging test should be performed with all Plugs.

Display

During maintenance, the screen should be checked using the physical buttons, as the screen is non-touch. All functions can be controlled through these buttons. If there is no issue with the button operations, the screen should be cleaned.

Distribution elements (MCCB, RCBO)

Distribution elements (MCCB, RCBO) should be checked and tightened when going for maintenance. These elements can be tightened with a screwdriver with a torque of 2 Nm.

AC input terminals

The AC input terminals should be checked and tightened when going for maintenance. These terminals should be tightened with a torque of 8 Nm for metric 8 bolts and 10 Nm for metric 10 bolts.

DC relay terminals

DC relay ends should be checked when going for maintenance. Tightening process should be performed with 6.5 Nm.

DC output cable and terminals

DC output cable and terminals should be checked when going for maintenance. They should be checked for any damage.

Fan

Fans should be checked when going for maintenance. In case of any breakage or damage, the damaged fan must be replaced. If there is no problem with the fans, a charging attempt should be made. It should be checked whether the fans rotate during this charging.

Body

The outer cabinet should be cleaned when going for maintenance.

Grounding resistance

A mechanism for measuring with a megger should be installed when going for maintenance. After the piles are driven, the voltage between the two piles should be less than 1V.

In cases where product transportation is required

During lifting, it is necessary to use 2 ropes of min 540mm (in case of using a single rope of $L_{min}=1080\text{mm}$, the rope must be fixed from the middle lifting part).

During lifting, there should be a minimum angle of 60 degrees at both rope ends as shown in the image. Using a shorter sling will cause damage to the product.

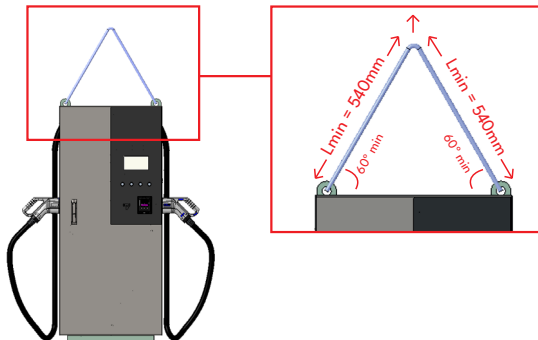

12 - WIRELESS LAN TRANSMITTER SPECIFICATIONS

Frequency Ranges	Max Output Power
2400 - 2483,5 MHz (CH1 - CH13)	< 100 mW
5150 - 5250 MHz (CH36 - CH48)	< 200 mW (*)
5250 - 5350 MHz (CH52 - CH64)	< 200 mW (*)
5470 - 5725 MHz (CH100 - CH140)	< 200 mW (*)

(*) '< 100 mW' for the Ukraine

Country Restrictions

This Wireless LAN equipment is intended for home and office use in all EU countries, the UK and Northern Ireland (and other countries following the relevant EU and/or UK directive). The 5.15 – 5.35 GHz band is restrictions indoor operations only in all EU countries, the UK and Northern Ireland (and other countries following the relevant EU and/or UK directive). Public use is subject to general authorisation by the respective service provider.

Country	Restriction
Russian Federation	Indoor use only
Israel	5 GHz band only for 5180 MHz-5320 MHz range

The requirements for any country may change at any time. It's recommended that user checks with local authorities for the current status of their national regulations for both 2.4 GHz and 5 GHz wireless LANs.

Hereby, Vestel Mobilite SAN. VE TİC. A.Ş., declares that the radio equipment type EVC is in compliance with Directive 2014/53/EU and Radio Equipment Regulations 2017. The full text of the EU declaration of conformity is available at the following address: doc.vosshub.com.

VESTEL

MOBILITY

VESTEL MOBİLİTE SANAYİ VE TİCARET A.Ş. EGE SERBEST BÖLGE ŞUBESİ

Zafer SB Mah. Ayfer Sok. No:22 İç Kapı No:1 Gaziemir, İzmir/ TÜRKİYE

Telefon (pbx) : 90 (232) 251 72 90 Fax : 90 (232) 251 73 13

Gaziemir V.D. : 837 001 0241

